

How Much DC Power Is Necessary?

Dr. Steven B. Leeb, Dr. James L. Kirtley, Jr., Warit Wichakool, Zachary Remscrim,
LT Chad Tidd, LT J. Andrew Goshorn, ENS Kevin Thomas, Dr. Robert W. Cox, Rachel Chaney

ABSTRACT

Many proposals for future power systems for warships are extant. Anticipated improvements in capability, operating economy, and signature reduction may not be uniquely associated with these power systems. Alternatives are available for constructing variable speed drives and prime movers for ships with electric drives. These alternatives may open new design possibilities.

INTRODUCTION

Ship designers working now and in the near future face the “curse of dimensionality.” Growing arrays of options and solutions are available for nearly every aspect of a ship design: materials, control and automation systems, weapons systems, power sources, power distribution systems, propulsion, hull design options, and more. Choices in any one dimension affect options in many or all dimensions, increasing the challenge of designing a vessel that provides peak capability, survivability, and maintainability at the lowest reasonable life-cycle cost.

Since at least World War II, there has been a steady technological pressure increasing not only the performance but also the complexity of many weapons systems. Combat aircraft are illustrative, benefiting from advances in materials, avionics, propulsion, and airframe design. These advances and their associated performance enhancements have “changed the calculus of strike from sending multiple aircraft to destroy a single target to sending one aircraft to destroy multiple targets” ([1], in reference to JDAM). These benefits come with a price. Field “repair” has essentially become a matter of replacement. Problems in key systems are ultimately resolved with depot-level maintenance, and field service depends either on the availability of spare modules or the ability to operate the system absent a malfunctioning subsystem. Generally, this trade-off is tolerated because there is no choice. Ceding the “high ground” afforded by advanced avionics and propulsion systems, for example, would open an immediate advantage for a motivated, technologically sophisticated opponent.

Future naval combat vessels stand on the threshold of this complexity/capability trade-off. In some cases, systems like advanced radar require a level of performance that may only be achieved with sophisticated “depot-repairable” modules. Field replacement of modules keeps such systems operating.

Increased demand for electrical power in projected future naval combatants with electric drive, advanced sensors, and electrically actuated weapons and launch systems motivates the consideration of new power systems architectures [2]. This consideration includes potentially extensive use of DC power distribution, i.e., a medium voltage direct current or MVDC power system [2]. Development of MVDC power systems for naval combatants is posited to provide many operational benefits, and will entail technological risk.

Practical MVDC power systems are likely to require mission-critical modules or subsystems that are at most “line replaceable,” i.e., subsystems that can be replaced in the field but repaired only at a depot-level facility. Many assumptions about future field conditions and operational scenarios are implicit in any decision to implement full MVDC power distribution on combat vessels. Loss of some key components in an MVDC power system could cripple the operational capability of a ship. Recovery of a damaged ship with an MVDC power system may require replacement modules, possibly from off-board the ship, implying a commanding access to the damaged vessel and its environs, including a *de facto* requirement for air transport and air supremacy.

Are we comfortable with a combat vessel whose “heart beat” increasingly depends on modules that can only be replaced, but not serviced, in the field? What will such a vessel cost to construct? If full MVDC is the only means to achieve peak combat capability and survivability, we are obligated to consider developing and deploying this type of power system. However, if equivalent combat capabilities can be achieved using power systems with less technological risk and lower cost, we are equally obligated to consider other options.

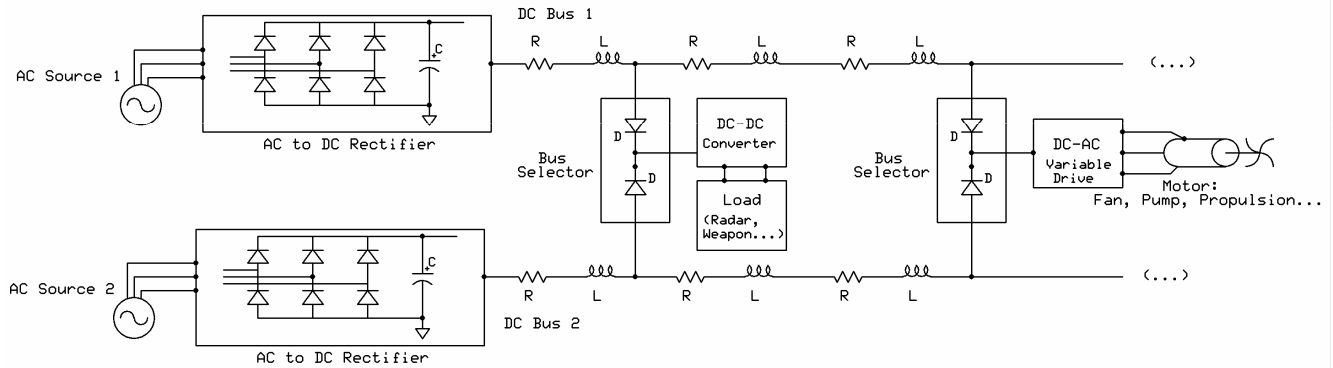

Figure 1: Multi-bus DC power distribution

This paper reviews some of the anticipated benefits and open concerns and questions associated with an MVDC power system architecture. The following sections examine alternatives for prime movers and variable speed electrical propulsion drives that might make a hybrid power system, with both AC and DC power, i.e., an “MVADC” system, attractive. A brief review of techniques for converting AC to DC power is conducted.

This discussion is necessarily speculative with regards to what might be best for any given ship, and is intended to be thought-provoking as opposed to argumentative. The “best” power system for any particular ship will depend on its size and mission. There may not be a single best option for all ships or even for a particular ship.

MVDC FEATURES

Reference [2] describes the MVDC architecture at a high level, leaving great flexibility for design and customization. Studies or analyses of hypothetical MVDC systems for shipboard application have focused on specific aspects of systems that could become practical MVDC systems. For example, in [5] and [6], the authors examine a two-bus architecture, essentially a port-and-starboard-oriented, split-plant operation of a shipboard power system. A schematic fragment generally illustrating this arrangement (but representing none of the references specifically) is shown in Fig. 1. To create a DC power system, two AC rotating machines are employed in Fig. 1. The electrical output of each of these machines is rectified and used to energize one of the two DC busses shown in Fig. 1, either “DC Bus 1” or “DC Bus 2”. Resistors “R” and inductors “L” represent parasitic line impedances. Power is distributed to ship loads through “Bus Selectors” that choose which bus energizes each load. Loads can draw power from either bus, but not both at the same time. In Fig. 1, the “Bus Selector” is illustrated with diode “OR’ing,” but other, potentially better performing alternatives are discussed in [5].

In a vision where all of the distributed power on the ship is DC (DC Bus 1 and Bus 2 in Fig. 1), essentially all loads interface to the power system through a power electronic interface. DC-DC converters transform voltage and current levels for electronic loads like radar, computers, and potentially some weapon systems. DC-AC converters create alternating voltage drives for loads like motors employed as pumps, fans, and – likely the largest of all electrical loads on the ship – the electric propulsion drive. In this vision, the AC-to-DC rectifiers, which interface the AC sources to the DC busses, must transform essentially all of the available AC power to DC, including all of the power for the ship propulsion drive.

This approach by the schematic fragment in Fig. 1, is anticipated to provide a number of benefits. Many of these are discussed in [2]. Some of these anticipated benefits include:

- **Efficiency:** Total conversion of all AC generated power to DC decouples the speed of the prime mover from the bus frequency. A gas turbine prime mover, for example, could be freed from operating at a fixed speed to maintain an AC bus frequency. Instead, the gas turbine speed could be adjusted to the power demand, improving fuel consumption.
- **Weight and volume:** The DC-DC converter shown in Fig. 1 represents a power electronic circuit that converts power from an input DC voltage and current level to new output DC levels appropriate for the load. These converters can operate at relatively high frequency – 100’s of kilohertz or more – and therefore employ lighter, smaller inductors, capacitors, and transformers compared to 60 Hz or similar frequency systems.
- **Improved acoustic signature:** In principle, without a common operating frequency, e.g., 60 Hz, the acoustic signature of the overall ship machine plant has a broader signature that would prove more difficult to identify and track.

- **Uninterruptible or “fight-through” power:** the multi-bus arrangement with a suitable bus selector can provide continuous power to loads even in the face of significant damage or casualty on one of the DC busses. In principle, a bus casualty on one side of the ship would cause loads to draw power from the remaining working bus through the bus selector. Only a catastrophic failure of all generation could interrupt power to the loads.

The general power system architecture suggested by the notional fragment in Fig. 1 is potentially reasonable if propulsion power is provided by a variable speed electric drive, and if the entire electric propulsion power must be provided by a DC bus energizing the variable speed, DC-AC inverter for the propulsion motor. The propulsion motor is likely the largest electrical power consumer on this hypothetical ship. In this case, since most of the generated power must be made available as DC power for the propulsion drive, it is probably reasonable to convert all of the power on the ship to DC, providing both propulsion power and the additional power necessary to run radar, electric weapons, and all of the other loads on the ship. The perceived benefits of MVDC distribution are concomitant with the assumption that full DC propulsion power must be available and might as well be distributed everywhere on the ship. The mechanical prime mover could, in this case, turn at variable speeds and achieve associated fuel economies, as well as moving operating acoustic signature off of a fixed frequency. Weight and volume could be saved by employing high frequency switching power converters on the DC side of the distribution system, and, with the right bus selectors, a degree of uninterruptible power may be achieved.

However, this approach has interesting costs, and may create critical bottlenecks or damage choke-points. The two “AC-DC rectifiers” shown in Fig. 1 convert the AC source power to DC and energize the associated DC busses. At the power levels anticipated, i.e., for ship propulsion load plus other loads, these rectifiers cannot be passive diodes. As will be shown shortly, the harmonic currents created by unfiltered rectification are unlikely to be acceptable for the AC generators. The AC-to-DC rectifiers will require either active or passive filtering to ensure that the current waveforms imposed on the AC generators are substantially sinusoidal and at the operating frequency of the generators. At the power levels required for converting the total ship power, including propulsion power, a passively filtered rectifier will probably weigh too much and require too great a volume to be practical on most ship designs. An active or high-frequency switched rectifier will likely be needed to provide an

appropriate load for the AC generators, an adequate output for the DC bus, and a reasonable package in weight and volume. In the event of damage, the solid-state electronics in the AC-DC rectifiers will most likely be “repaired” by replacement of modules, if available. If not available, failure of these rectifiers will cripple the ship.

Is total conversion of all electrical power on the ship to DC necessary or desirable?

At least in the case of gas turbine prime movers, it is unclear that variable speed operation is a primary means for improving fuel economy. A combined-cycle prime mover would offer many possible design benefits. The efficiency improvement with combined cycle and co-generation could be 50% or more over existing USN gas turbine power plants, e.g., the LM2500 deployed in the Arleigh-Burke destroyers.

DC distribution is not necessary to achieve automation and reconfiguration. With an AC distribution system, electronics can still be used to automate the operation and reconfiguration of loads like workhorse motors. Automation electronics failure is not necessarily a mission-cripple in this case, as the rudiments of operating a motor – a functioning motor and an AC power source – may be available to the watch stander even if control electronics fail on an AC system.

Without substantial AC distribution on the ship, essentially every workhorse motor will need a power electronic drive. As a point of reference, a survey of a 270 foot “Famous”-class US Coast Guard cutter like *USCGC Escanaba* revealed over 72 rotating electric machines, at least 22 of which are typically operating during underway operations. These motors include lube oil pumps, cooling water pumps, hydraulic pumps, and fan motors. Underway, they typically demand 355 A from the main electrical service (summed for all three phases), or a total of over 150 kW, over half of the ship’s electrical generating capacity. These numbers are likely to scale up quickly for larger ships. In an MVDC power system, every motor will require a power electronic drive to invert available DC power into AC drive waveforms. These DC-AC inverters become additional opportunities for decreased MTBF. As casualties, they are critical – there will be no way to operate a motor on the ship without a functioning DC-AC inverter.

Speculating from aerospace experience, widespread use of high-frequency switching power electronics will require a new level of emphasis on electrical bonding to ensure that an MVDC ship is robust in the presence of electrical assaults like lightning and EMP.

The benefits of MVDC *per se* for reducing acoustic signatures are also unclear. At the risk of oversimplifying the “cat and mouse game” of electronic signal intelligence, it is unclear that a ship can achieve acoustic stealth by changing from one steady plant operating frequency, e.g., 60 Hz, to a variable but quasi-static (constant over short times, e.g., minutes) frequency maintained during a particular ship state. Very generally, signature reduction is achieved by eliminating frequencies sustained even for short times, or by “spreading” signal energy over many frequencies to greatly reduce any particular content peak, or by hiding signal energy in a benign background signal that serves as camouflage. A variable frequency gas-turbine prime mover will still operate at some nearly fixed frequency over short durations. In an efficiency enhancing scheme, these frequencies are likely to be lower than the conventional operating frequencies currently employed on the LM2500, for example. Lower frequencies are likely detectable at relatively more distant ranges [2], and an important source of these frequencies, the gas turbine and associated generator, is unlikely to go away in MVDC.

MVDC might reduce aggregate plant noise from workhorse motors by running them at different frequencies with variable speed drives. Will this benefit substantially improve the situation over intentionally equipping an AC-bus ship with different pole-pair motors operating at different slip frequencies? That is, how much acoustic signature benefit will MVDC provide for workhorse motors with respect to a carefully designed AC distribution system with renewed attention to motor operating frequency, slip, and mechanical mechanisms for attenuating acoustic noise? Other acoustic signature reduction techniques, e.g., renewed focus on mechanical mounting or operating techniques that cancel signature by counterbalancing mechanical operation, would benefit any power distribution system, not just MVDC.

It may be possible to radically improve fuel economy without DC power distribution. It may also be possible to create a variable-speed electric propulsion drive with significantly reduced requirements for DC power. If so, an alternate MVADC architecture could provide many of the sought benefits while eliminating architectural choke-points that could limit the robustness of the ship power system.

COMBINED-CYCLE POWER PLANT

Figure 2 shows a schematic representation of a combined-cycle power plant employing a gas-turbine primary power converter and a steam engine secondary

recovery converter nominally operating from the waste heat of the gas-turbine engine. Each engine turns a distinct electrical generator as shown in Figure 2, but this is not required. Both engines could be coupled to that same shaft powering a common electrical generator. This arrangement could be attractive if a fully “in-line” plant is mechanically convenient. Alternatively, the two-engine, two-generator approach shown in Fig. 2 might be more convenient for a hybrid

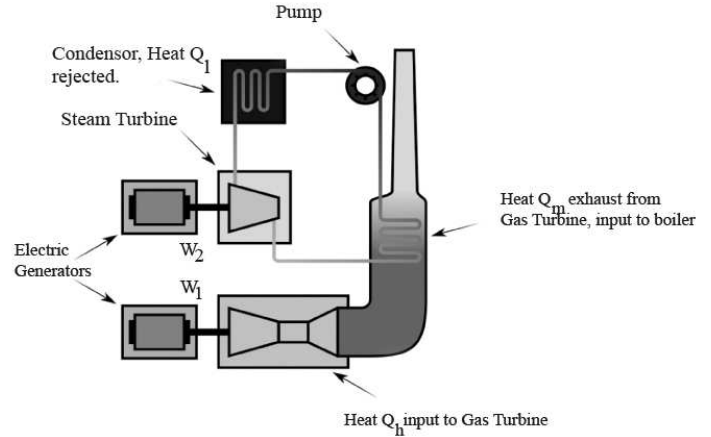

Figure 2: Combined-cycle power plant (illustration from Wikipedia, annotated by the authors).

ship plant, or to provide redundancy and spatial and electrical separation.

A combined-cycle plant is an exciting possibility for ship-board power generation for several reasons. The diversity of electrical generation might be advantageous for survivability. The efficiency of the combined-cycle plant can be remarkably greater than a gas-turbine or steam-fired engine alone.

The efficiency η of a heat engine is typically defined as the ratio of the shaft work W produced by the engine divided by the heat input Q to the engine:

$$\eta = \frac{W}{Q}$$

We can compare the efficiency η of a combined-cycle plant to the efficiency η_1 of the gas turbine engine alone by appealing to the first law of thermodynamics. For the gas turbine, the first law states that the output heat Q_m leaving the engine is equal to the difference between the heat input Q_h to the engine minus the shaft work W_1 performed by the engine, e.g., on the electrical generator:

$$Q_h - W_1 = Q_m$$

We seek an expression for η . Multiplying the first law balance on both sides by the ratio $W_2/(Q_m Q_h)$ yields an equation, recognizing cancellations, in terms of η_1 and η_2 (the efficiency of the steam engine operating from the waste heat Q_m of the gas turbine) on the left side:

$$\frac{Q_h W_2}{Q_m Q_h} - \frac{W_1 W_2}{Q_m Q_h} = \frac{W_2}{Q_h}$$

Adding the efficiency of the gas turbine to both sides

$$\frac{W_1}{Q_h} + \frac{W_2}{Q_m} - \frac{W_1 W_2}{Q_m Q_h} = \frac{W_1 + W_2}{Q_h}$$

and identifying the equation terms as efficiencies yields:

$$\eta_1 + \eta_2 - \eta_1 \eta_2 = \eta$$

which states that the efficiency of the overall combined cycle plant is equal to the sum of the efficiencies of the gas turbine and the steam engine, minus the product of the efficiencies of the two engines [7]. In [7], the author observes that for “ballpark” efficiency numbers of 40% for the gas turbine and 30% for the steam engine, the overall efficiency of the combined cycle plant is 58%, a remarkable improvement over either engine alone.

The potential system efficiency improvement offered by a combined-cycle plant for a warship could be even greater. The LM2500 plant [3] on the DDG-51 includes a 130 hp electric fan used to provide cooling air for the gas turbine, and also cooling air to mix with the turbine exhaust to reduce the ship’s thermal signature. A combined-cycle plant could run with considerably cooler final exhaust, and might afford a significant savings on the cooling air needed for thermal signature reduction. Further savings might also be gained if the combined-cycle plant were run with co-generation, using the final exhaust heat stream to produce hot water for the ship.

The promise of a combined-cycle plant for fuel economy is too great to ignore. The efficiency improvements that could be achieved with a combined-cycle plant likely far exceed what could be achieved by simply running the gas turbine at variable speed. Of course, the two ideas, variable speed operation and combined-cycle, could both be deployed in the same plant. The combined-cycle plant also offers interesting design flexibility for redundancy and backup operation. In an emergency, for example, the steam engine in the plant could be fired directly by an auxiliary burner if

the gas turbine was unavailable. The plant could be used to make a hybrid electromechanical drive for propulsion. DC and AC generation could be mixed and distributed in useful fractions between the two engine stages, providing redundant power for both AC and DC busses.

A redesign of the core power plant, regardless of electric bus selection, could yield remarkable new options and benefits for 21st century warships. The question of bus selection, DC or a mix of AC and DC, largely becomes a question of the needs of the variable-speed propulsion drive. There is an option for constructing a variable-speed propulsion drive that does not require all or even most of its input power from a DC bus.

VARIABLE-SPEED ELECTRIC DRIVE

The propulsion power required by a displacement-style hull grows rapidly with speed. The torque required to turn a propeller is generally a nonlinear function that increases with speed. A model of required shaft torque τ as a function of shaft speed Ω might, for sake of discussion, be modeled with a square-law dependence

$$\tau = \beta \Omega^2$$

where β is a constant related to the effective viscosity or “resistance” seen by the propeller in seawater. Shaft power P_m is the product of shaft torque and shaft speed:

$$P_m = \tau \Omega = \beta \Omega^3$$

For any particular ship design, there will be a design-maximum shaft power P_o associated with a maximum shaft speed Ω_o . At any speed, we find “Observation 1:” the ratio of shaft power to the cube of shaft speed might be modeled as constant:

$$\beta = \frac{P_m}{\Omega^3} = \frac{P_o}{\Omega_o^3}$$

Figure 3 shows a plot of normalized shaft power versus normalized shaft speed. That is, maximum power P_o and speed Ω_o are each indicated on the graph at unity on the vertical and horizontal axes, respectively.

It is possible to exploit the rapid growth of shaft power with speed to construct a variable drive that draws the bulk of its power from a fixed frequency AC source at high speeds. The argument that follows is applicable to any situation where shaft power grows monotonically with speed; that is, the choice of a cubic model relating

shaft power and speed is for illustration, although this is likely to be a reasonably representative model.

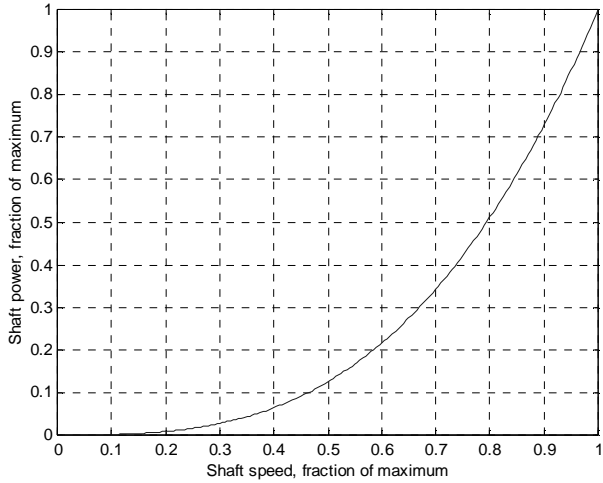

Figure 3: Normalized propulsion power

Doubly-Fed Machine

The proposed drive employs a wound rotor induction machine as the propulsion motor, sometimes called a doubly-fed machine or DFM here. This type of machine is used in electric power generating windmills. The DFM has windings on both the stator and the rotor. Electrical contact to the rotor windings is made through a set of slip rings. The stator and rotor windings can be operated shorted, or energized with DC current, or driven with a fixed or variable frequency AC source. Several different combinations of winding excitation produce a useful motor. For example, with the rotor windings shorted and the stator driven with a fixed frequency AC source, the DFM operates in a manner essentially identical to a conventional squirrel-cage induction machine.

Figure 4 shows the “steady-state” circuit model of the DFM, which can be useful for understanding the operation of the machine. The machine is essentially similar to a transformer, with primary windings on the stator and secondary windings on the rotor. The circuit model in Fig. 4 is similar to the conventional “T-model” used to represent a single-phase transformer or one phase of a line-neutral stator connection on a wye-wound squirrel-cage induction machine. The model components V , $R1$, $L1$, and Lm in Fig. 4 represent the stator applied voltage, resistance, leakage inductance, and magnetizing inductance, respectively. The vertical line through the nodes labeled “a” and “g” is the “air-gap” line, which marks the point in the circuit model separating lumped model elements on the stator from

those on the rotor. The model components $L2$, R , and Vr represent rotor leakage inductance, resistance, and source voltage, respectively. These components have

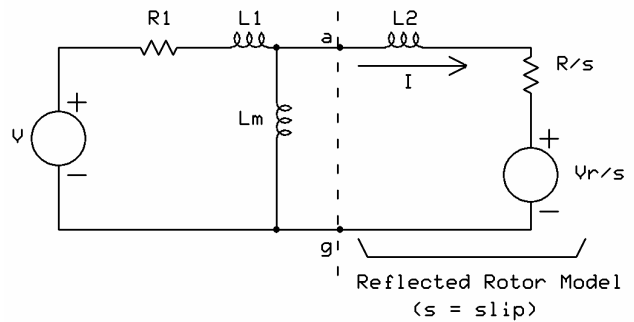

Figure 4: DFM steady-state circuit model

been reflected across the “ideal transformer” that could otherwise be included in the model, and also have been scaled as appropriate by slip to account for the relative motion between the stator and the rotor. The slip “ s ” is the unitless quantity that represents the difference between the stator frequency and the shaft speed times the number of pole pairs, all divided by stator frequency. In a squirrel-cage machine, the rotor windings are shorted together, and the source Vr can be replaced by a short. In the DFM, a rotor voltage Vr can be applied through the slip rings. A current I is induced in the reflected rotor components to the right of the air-gap line in Fig. 4.

A key to understanding the DFM is the recognition that that reaction torque on the stator must equal the motive torque on the rotor. This observation can be expressed quantitatively by examining the power transfer from the electrical sources driving the machine, V and Vr in Fig. 4, to the mechanical shaft. Net real power P_{ag} flowing left-to-right in Fig. 4 across the air-gap line must come from the stator source. Power can also flow from the rotor source Vr , but no **net** real power from the rotor source contributes to P_{ag} – any power flowing left-to-right across the air-gap line from the rotor source must first flow right-to-left across the air-gap line, for a net zero contribution crossing the air-gap line. Ignoring ohmic losses in $R1$ on the stator, and a constant factor for the number of phases, and assuming that the rotor power electronics are controlled to deliver real power, the net real power delivered by the stator source is approximately equal to the net real power crossing left-to-right across the air-gap line:

$$P_s \approx P_{ag} = I^2 \frac{R}{s} + I \frac{Vr}{s}$$

The rotor inductance L_2 absorbs no real or average power. Some of the real power P_{ag} performs electro-mechanical work, and the remainder is delivered to the electrical elements R and V_r in the rotor circuit. The component of power P_{ag} performing electro-mechanical work, P_m , is the difference:

$$P_m = P_s - I^2 R - I \cdot V_r = P_s (1 - s)$$

The actual steady-state shaft speed of the DFM, Ω , is by definition related to the synchronous shaft speed, Ω_s (the stator electrical frequency divided by the number of pole pairs), by the slip:

$$\Omega = \Omega_s (1 - s)$$

The shaft torque is the quotient of shaft power P_m divided by shaft speed, which is now visibly identical to the real power provided by the stator source divided by the synchronous shaft speed:

$$\tau = \frac{P_m}{\Omega} = \frac{P_s}{\Omega_s}$$

This “Observation 2” implies the equivalence of the rotor and stator reaction torques, which can be conveniently expressed as either a ratio of mechanical or electrical power divided by the appropriate “speed” or frequency in the associated frame.

Propulsion Drive

At least two different operating configurations of the DFM concern us here for a ship propulsion application. We begin by assuming that the variable frequency power electronics associated with the rotor will only deliver power into the machine. This simplifies the analysis of the machine, and eases the requirements on the ship power system by avoiding the need to absorb regenerated power from the DFM. This assumption is not required, however, and the possibility of operating the DFM with bi-directional power electronics will be revisited shortly. The two operating configurations are illustrated schematically in Fig. 5.

In the **first** operating configuration, the DFM stator is energized with DC excitation. In essence, the stator serves as an electromagnet, creating a fixed set of north and south magnetic poles in the fixed, non-rotating reference frame of the ship. The rotor is energized with variable frequency AC waveforms from a power electronic drive. In this configuration, the magnetic field patterns created by the stator and rotor with power electronic drive are much like a classic, brushed, “Edison-style” wound-field DC motor. Of course, the

DFM has no mechanical commutator, only slip rings – the variable speed drive for the rotor serves as an “electronic commutator,” and the machine is capable of producing torque. The DC power used to energize the stator is likely to be negligible, limited to the ohmic losses on the stator. Some significant, to be minimized, DC power will be needed to energize the variable frequency power electronics associated with the rotor.

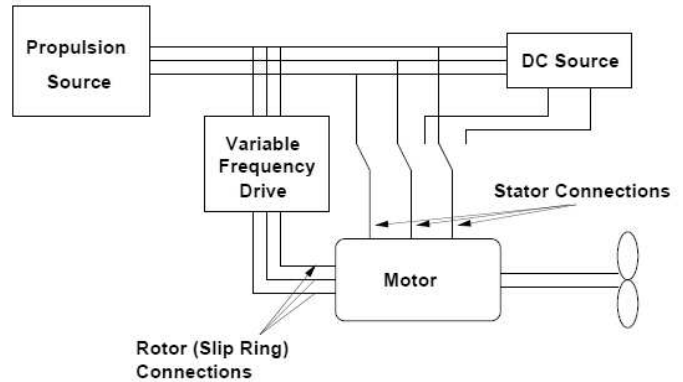

Figure 5: Doubly-fed machine (DFM) for propulsion

A threshold in operating condition is reached when the stator is energized with DC current and the rotor receives AC waveforms from its power electronic drive that are at the same frequency as the synchronous or utility electric frequency, assumed fixed, on the ship. At this point, the machine could be operated in either of two configurations, either of which will produce identical torque and speed.

The DFM could be operated with DC current on the stator and AC created by the rotor power electronics at synchronous utility frequency on the rotor. Alternatively, at this synchronous shaft speed Ω_s , the rotor could be energized by a DC current, and the stator could be powered by the fixed-frequency AC bus that is conventionally available on most ships. This alternative configuration creates a magnetic field pattern typically associated with a “brushless” DC or permanent magnet synchronous machine. If the DFM operates with fixed-frequency AC on the stator and DC current (zero frequency) on the rotor, it runs at synchronous speed. Rotor power drops to just the ohmic dissipation associated with running the rotor windings at DC – likely a negligible amount of power.

The DFM rotor can be further accelerated in a **second** operating configuration, with the stator connected to the fixed frequency AC source and by energizing the rotor with the power electronic AC drive. Rotor power, increasing from zero at synchronous shaft speed, is

again delivered to the rotor from the variable frequency power electronic drive, accelerating the rotor past synchronous speed. The machine operates with negative slip. Significant power is also delivered to the machine stator from the fixed-frequency AC source.

In summary, if the goal is to minimize the total amount of DC power needed for the propulsion drive, and also to operate the power electronics strictly with electric power delivery into the DFM, avoiding the need to regenerate electric power on to the ship power system, the machine would begin operation at zero speed in the first configuration. With the stator energized by DC current, the rotor is energized by the power electronics, gradually increasing in power, electrical frequency, and shaft speed to any required operating frequency below synchronous shaft speed. At this “cutover” or synchronous shaft speed, the rotor electrical power reaches its peak, and the machine is transitioned to the second operating mode. The stator is disconnected from the DC supply, allowing enough time, likely tens of milliseconds, for the DC current to decay, and then connected to the ship’s utility AC supply. Once the AC supply is connected to the stator, the rotor can be excited, most likely by power electronics configured to look like an adjustable frequency current source that will inject current to “push” against the rotating flux wave created by the stator.

The rotor power electronics can be limited to a peak power level equal to the needed rotor power at the synchronous shaft speed. The peak shaft speed, which exceeds synchronous shaft speed, will occur in the second operating mode as the rotor accelerates past synchronous speed. The rotor electronics eventually reach peak operating power for a second time. Equating the rotor power requirement at the end of the first operating region at synchronous speed with the level at the end of the second operating region at full shaft speed permits determination of the power rating requirements for the rotor electronics.

We write the rotor power equations for each of the two operating configurations. In the **first** operating configuration, the rotor power P_r provided by the power electronics is equal to the mechanical power P_m . Employing the previous “Observation 1,” essentially all of the motive power for the DFM in “low-speed” operation comes from the rotor power electronics:

$$P_r = P_m = P_o \left(\frac{\Omega}{\Omega_o} \right)^3$$

In the **second** operating configuration, the rotor power is equal to the difference of the shaft power and the real

stator power, i.e., the “extra” shaft power not provided by the stator. This equivalence can be written using both “Observation 1” and “Observation 2”:

$$P_r = P_m - P_s = P_o \left(\frac{\Omega}{\Omega_o} \right)^3 \left(1 - \frac{\Omega_s}{\Omega} \right)$$

To determine the necessary rating of the rotor power electronics, we can equate the rotor power at synchronous shaft speed at the end of the first operating region with the rotor power at maximum shaft speed at the end of the second operating regime:

$$P_o \left(\frac{\Omega_s}{\Omega_o} \right)^3 = P_o \left(1 - \frac{\Omega_s}{\Omega_o} \right)$$

Identifying the ratio of synchronous shaft speed to maximum shaft speed as f_s , this equation can be simplified to

$$f_s^3 + f_s - 1 = 0$$

Solving this equation yields $f_s = 0.68$ for practical values. For this example where propulsion power increases as the cube of speed, the synchronous shaft speed will be located at 68% of full shaft speed, assuming rotor power electronics rated for the propulsion power required at synchronous shaft speed. Different values for f_s will be found for speed/power relationships that are other than cubic, but this result is generally representative of what is likely.

Now, the rotor power equations can be used to plot normalized rotor power as shown in Fig. 6 over the full shaft speed variation. For speeds below the synchronous shaft speed, i.e., approximately 0.68 on the horizontal scale, the DFM operates in the first operating configuration. Essentially all of the shaft power is provided by the rotor. Past this speed, the DFM operates in the second configuration, with motive power supplied to the shaft by both the stator and rotor. The normalized stator electrical power at any operating speed, shown in Fig. 7, is the difference between the mechanical shaft power in Fig. 3 and the delivered rotor power in Fig. 6 at the particular shaft speed. As indicated in Fig. 6, the rotor power peaks at two operating speeds, the synchronous shaft speed and the peak shaft speed at unity.

For this example, the maximum required power for the rotor, and therefore the DC bus powering the rotor drive, is ideally limited to less than a third of peak propulsion power.

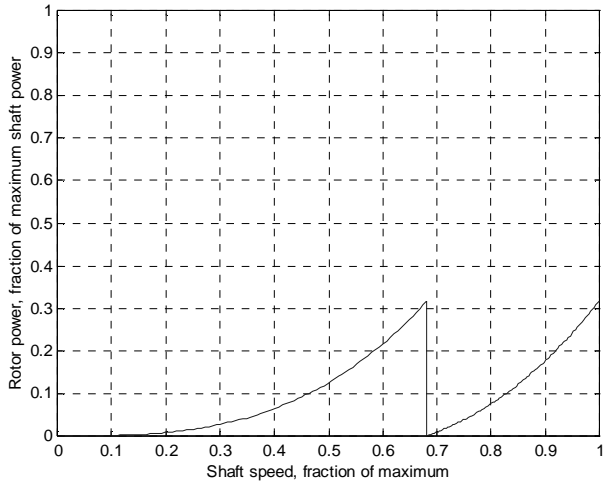

Figure 6: Normalized DFM rotor power – unity on the vertical and horizontal axes correspond to maximum power P_o and speed Ω_o .

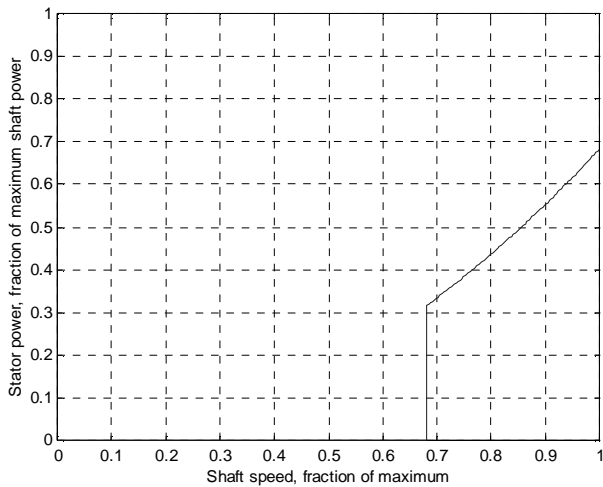

Figure 7: Normalized DFM stator power – unity on the vertical and horizontal axes correspond to maximum power P_o and speed Ω_o .

If the rotor power electronics can operate reversibly, i.e., with the ability to transfer power to or from the rotor, the required peak power electronic rating can be further reduced [8]. This would therefore further reduce the amount of DC power required to energize the propulsion drive. However, the ship power system would have to be able to accept regenerated power from the rotor power electronics. This is no problem in principle, but may have implications for power quality and system stability that need further exploration.

MVADC POWER SYSTEM

With reduced requirements for DC power afforded by the DFM, virtually all of the anticipated benefits of MVDC might be achieved with a hybrid MVADC power system suggested by the system fragment shown in Fig. 8.

This MVADC system offers several additional potential benefits. The MVADC architecture retains substantial capability for AC power delivery, both for the propulsion drive and also for other workhorse AC motors around the ship. These workhorse motors no longer require a full high-frequency DC-AC inverter, and could be controlled with simpler electronics for basic automation if required. “Uninterruptible” power delivery to DC loads can also be retained. If the system is operated split-plant, the bus-tie shown at the far right in Fig. 8 can be left open. In this case, the port AC and DC busses operate independently of the starboard, and DC loads retain the ability to “bus select” in the event of an interruption on one of the DC busses. The system could also be operated with the bus tie connecting the two AC busses, permitting the AC generators to operate in parallel. The illustrated bus tie represents possible bus ties throughout the ship, retaining the possibility to protect the AC power distribution with proven zonal protection devices like the multi-function monitor (MFM) currently in use on DDG-51 [4].

With a reduced requirement for DC power, useful alternatives may become available for creating the DC busses.

The topology of a simple three-phase rectifier is shown in Figure 9. The six diodes in the rectifier create a DC bus across the output capacitor, powering a load represented as a resistor in this illustration. The rectifier draws a distorted waveform of line current. Line waveforms, produced from simulating this three-phase rectifier, are shown in Fig. 10. The distorted line current waveform shown in Fig. 10 contains substantial fifth and seventh harmonic components. These higher harmonics will flow in the ship AC generators, and will create heating and other effects in the generators that are likely to be unacceptable.

There are several options for eliminating these harmonic currents from the ship power system at-large. The passive rectifiers in Fig. 9 can be replaced with an active, high-frequency switching circuit with active control for harmonic reduction. With adequate cooling, this provides a compact solution for creating a DC bus without introducing excessive harmonics in the

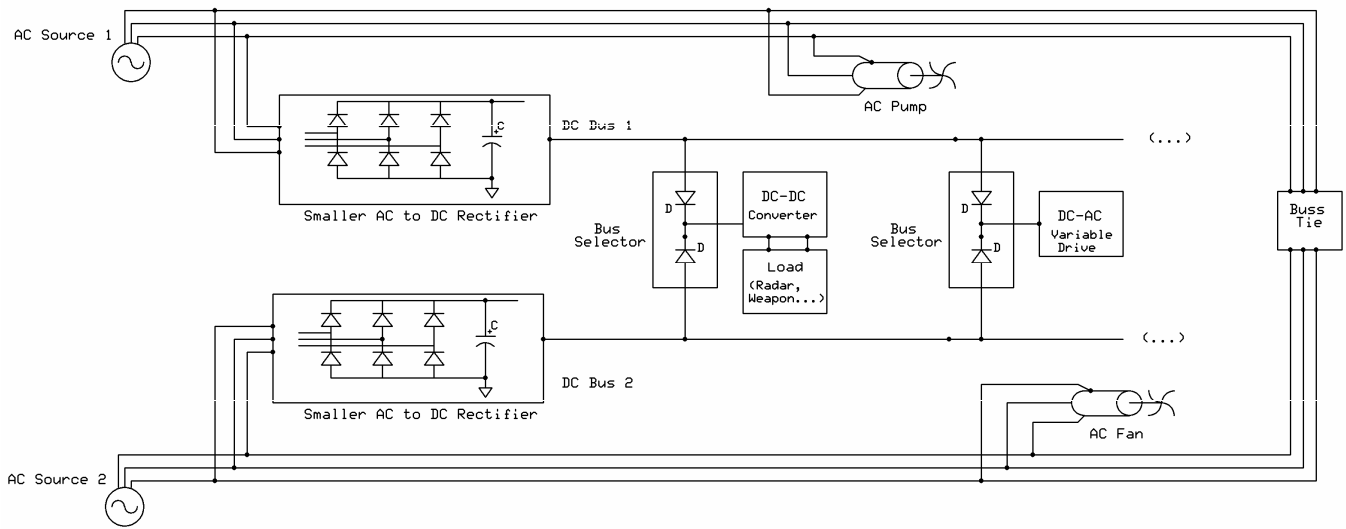

Figure 8: Multi-bus AC and DC power distribution

AC generator. Active rectification would most likely be required on an MVDC system, where all AC power is converted to DC. In this case, the ship is at the mercy of the availability of the active rectifiers. These components are most likely “repaired” by replacement, and a loss of all active rectifiers on an MVDC ship would likely be a mission cripple.

With the reduced requirement for DC power on the MVADC power system incorporating a DFM drive, it might be possible to create one or all of the DC busses using a passively filtered rectifier [11]. The passively filtered rectifier will almost assuredly weigh substantially more than the active solution. However, the additional weight and volume may not be unacceptable, particularly if the weight of the filtering elements can be incorporated in the ship design as ballast. A passively filtered rectifier, like the harmonic-trap filter shown in Fig. 11 [9], [10], has an interesting potential benefit. In the event of damage, it may be possible to “wire around” the filter elements, creating a DC bus with an emergency configuration like the rectifier shown in Fig. 9. A reduced amount of DC power would be available quickly with a reconfiguration that could be conducted by watch standers, automated or human, in the field.

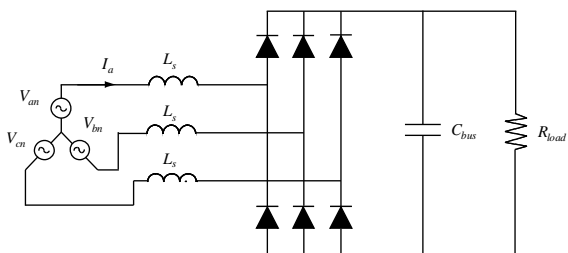

Figure 9: Three-phase rectifier

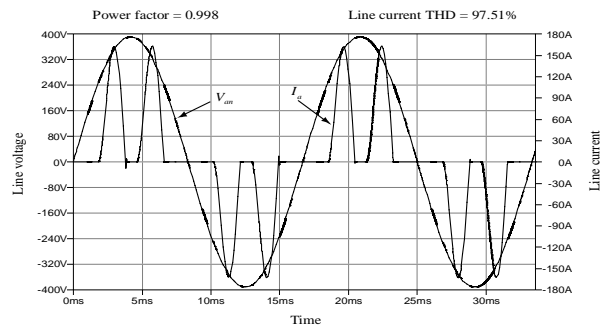

Figure 10: Simulated line waveforms

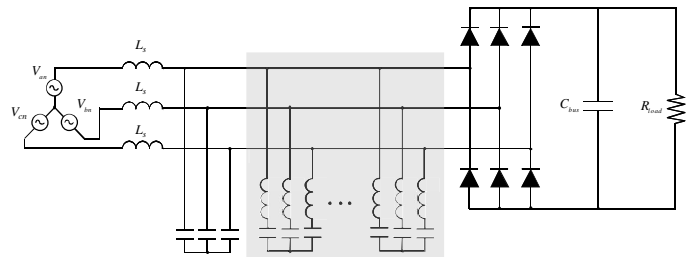

Figure 11: Passive power factor correction with harmonic-trap filters.

CONCLUSION

Future power systems for naval combatants may benefit enormously if we consider the system as a whole, including new options for the prime mover and propulsion drive. What level of field repair capability do we wish to retain? Are options like combined-cycle power generation plants, possibly with co-generation, valuable design alternatives that could enhance both the design flexibility and also the operating economy of future warships? How are enhanced requirements for signature reduction best

incorporated in future designs? Will future weapon systems require direct DC power, or will they, with equal or greater flexibility, “spin up” from an AC source, storing energy internally for pulse operation?

In principle, a solution, the DFM, is available for constructing a variable-speed propulsion drive for a warship. The DFM does not demand all or even a majority of the propulsion power from a DC bus. There are many open questions concerning the feasibility of a practical DFM. Slip rings are required for operating the machine. The rating of these slip rings is likely to be larger than, but not necessarily substantially larger than, slip rings currently employed on utility turbo-generators. The ratings for these slip rings could be further reduced if bi-directional operation of the rotor power electronics is acceptable for the ship’s power system. The geometry and modularization of the DFM for shipboard application both need further study. We are also exploring the trade-offs associated with different approaches for power factor and harmonic correction for generating the DC bus.

ACKNOWLEDGMENTS

The authors gratefully acknowledge the assistance of the crews of the *USCGC Escanaba* and *USCGC Seneca*. Their patience has been indispensable. This work was supported in part by the Grainger Foundation, the U.S. Navy through ONR’s ESRDC program, and NAVSEA.

REFERENCES

1. Air Force Magazine, “The Testers from Tucson,” December 2009, pg. 48.
2. CAPT Norbert Doerry. Next Generation Integrated Power System: NGIPS technology development roadmap. Technical report, Naval Sea Systems Command, November 2007.
3. Naval Sea Systems Command. Technical Manual Organizational Level Maintenance LM2500 Propulsion Gas Turbine Module Description and Operation, S9234-AD-MMO-010/LM2500, revision 3 edition, May 2000.
4. David Wipf and Eugene Parker, Jr., Demonstration and Assessment of High Speed Relay Algorithm, Technical Report, Barron Associates, June 1997.

5. Robert Balog and Philip Krein, “Bus selection in multibus DC power systems,” IEEE Electric Ship Technologies Symposium, May 2007.
6. M. Bash, R. R. Chan, J. Crider, C. Harianto, J. Lian, J. Neely, S. D. Pekarek, S. D. Sudhoff and N. Vaks, “A Medium Voltage DC Testbed for Ship Power System Research,” IEEE Electric Ship Technologies Symposium, April 2009.
7. Lee S. Langston, “Efficiency by the Numbers,” *ASME Mechanical Engineering*: http://memagazine.asme.org/Web/Efficiency_by_Numbers.cfm
8. James L. Kirtley, Jr., Slip Ring Motors for Ship Propulsion, White paper, Massachusetts Institute of Technology, May 2004.
9. J. Arrillaga and N. Watson, Power system harmonics (2nd ed.). Hoboken, NJ: John Wiley & Sons, 2003.
10. J. Das, Power system analysis: “Short-circuit load flow and harmonics.” New York: Marcel Dekker Inc., 2002.
11. R. Redl and L. Balogh, Power-factor correction in bridge and voltage-doubler rectifier circuits with inductors and capacitors. *Proc. Applied Power Electronics Conference and Exposition 1995*. Mar 1995. (1):466–472.