

Fiat Lux: A Fluorescent Lamp Digital Transceiver

Deron K. Jackson, *Student Member, IEEE*, Tiffany K. Buffaloe and Steven B. Leeb, *Member, IEEE*

Abstract— The prevalence of electric discharge illumination has led us to consider ways to use discharge lamps for communication. This paper describes an optical transceiver system which transmits by modulating the lamp arc. The prototype power electronic lamp ballast uses a pulse frequency modulation scheme which ensures no perceptible flicker.

Keywords— Fluorescent lamps, optical communication, electronic ballasts, optical modulation/demodulation.

I. INTRODUCTION

OVER half of the artificial light produced in the United States comes from lamps in which an electric discharge through a gas is used to produce illumination [1]. The prevalence of electric discharge illumination has led us to consider ways to inexpensively use discharge lamps for communication. This paper describes an optical transceiver system which transmits information by modulating the arc in a fluorescent lamp.

The basic idea of using lighting to send information as well as to provide illumination appears to have originated at least as early as 1975 [2]. In [2], the inventor discloses an analog amplitude-modulation (AM) scheme to modulate the arc current in a fluorescent lamp, the “carrier” signal, with an audio information signal. The more recent [3] discloses an updated electronic circuit that also provides for AM modulation of the arc current with an analog signal. In [4], a method for encoding low-bandwidth digital information into the lamp light using a pulsed AM technique was disclosed. The encoding technique involves chopping 100 microsecond slices of current out of the arc waveform. Other communication schemes have also been proposed that do not use the lamp light as the carrier, but instead use the lamp fixture as an antenna for transmitting conventional radio wave or microwave signals. In [5], for example, the inventors disclose techniques for mounting a microwave antenna on the glass surface of fluorescent and incandescent lamps.

This paper describes a transceiver system that frequency modulates the light output of a fluorescent lamp to achieve a relatively high bandwidth communication channel. Contemporary digital coding schemes are employed to maximize the transmitted data rate, and consideration is given to the frequency content of the light output of the lamp. The prototype transmitter is a switching power electronic ballast that uses a digital pulse-frequency modulation scheme [6] to ensure, in particular, that the lamp exhibits no flicker perceptible to the human eye. A portable receiver decodes the information encoded in the lamp light.

The received digital data stream could be used to deliver

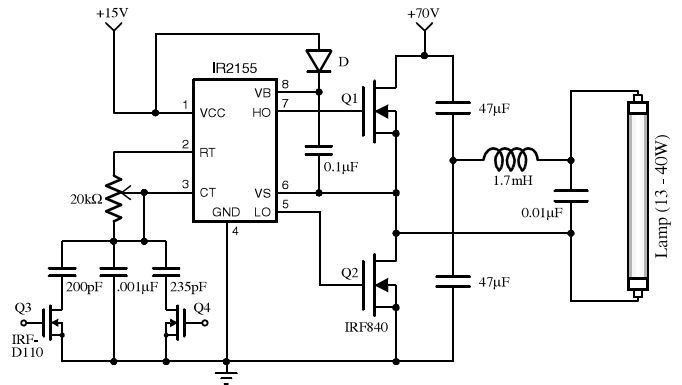

Fig. 1. Lamp ballast circuit.

a visual (text) or audio message, or could be processed directly by a computer or other information handling system. We envision, for example, that the transceiver system could be used to provide a continuous, personal audio signal to the visually impaired. This signal could change with different lighting zones in a building to provide a kind of audio map or positioning system. With the addition of a power line carrier modem or other real-time information delivery scheme, the transceiver could also be used as a paging or broadcast system. The lamp-based transceiver system could be advantageous in comparison to other communication schemes (e.g., custom infra-red or radio-frequency transceiver installations) because it can be installed, in principle, with no additional wiring beyond that required to install conventional light fixtures in a building or on a street. Also, light fixtures are typically arranged to flood an area with light, ensuring a relatively reliable communication channel.

The prototype transmitter is composed of a single, 16 inch fluorescent lamp in a fixture with a custom electronic ballast. The ballast transmits digital messages stored in an EEPROM. The receiver consists of an Intel 80C196KC microcontroller board [7] and an analog preprocessor, which recovers digital data by demodulating the output of an optical detector. The microcontroller displays received messages on a liquid crystal display. The next section reviews the design of the transmitter and lamp ballast. The section following describes the receiver, and the paper concludes with a review of experimental results.

II. TRANSMITTER

The luminosity of a fluorescent lamp is related to the frequency and amplitude of the arc current running through the lamp [1],[8]. Either the frequency or amplitude of the arc current could be varied to “key” information into the light output of the lamp. Of course, any variations must

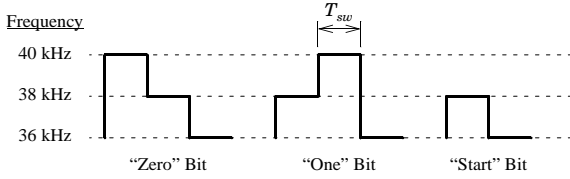

Fig. 2. Three-level bit patterns.

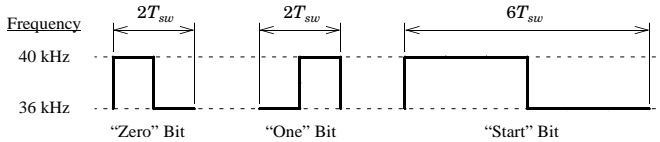

Fig. 3. Manchester bit patterns.

occur at a rate substantially above the range of visual perception to avoid visible flickering of the lamp light. Low frequency flicker has been linked to eyestrain and headaches [9]. The prototype demonstrates two pulse coding schemes that shift the arc frequency to avoid such low frequency flicker.

The lamp ballast employed in the prototype is a Class-D series-resonant parallel-loaded inverter ([10], [11]) built using the International Rectifier 2155 lamp ballast controller chip [12]. The ballast circuit is shown in Fig. 1. Note, in particular, that the RC timing circuit connected to pins 2, 3, and ground on the IR2155 has been modified from the typical timing circuit shown in [12]. The net effective timing capacitance can be selected by turning *on* or *off* one of the IRFD110 MOSFET's (Q3 and Q4). With both MOSFET's *off*, the lamp operates at an arc frequency of approximately 40 kHz. With Q3 *off* and Q4 *on*, the arc frequency is 38 kHz. With both MOSFET's *on*, the arc frequency is 36 kHz.

To transmit a data bit, it is *not* sufficient to employ, for example, a direct frequency-shift-keying (FSK) scheme. Suppose a zero bit was assigned an arc frequency of 36 kHz and a one bit was assigned 40 kHz. In this case, a long run of logic zeros followed by a long run of logic ones would result in a noticeable flicker in light intensity during the transition. Instead, coding schemes are used that result in a steady light output, on average, with no perceptible flicker. Two such coding schemes are shown schematically in Figures 2 and 3. The first, a three-level code, shifts the arc frequency to one of the three possibilities every $T_{sw} = 2$ milliseconds. The result is a steady light output, on average, with no perceptible flicker. A one or a zero bit does not correspond to a particular arc frequency, but rather, to a three level pattern in arc frequency. A logic zero bit is transmitted by varying the arc frequency first to 40 kHz, then to 38 kHz, and finally to 36 kHz. A logic one bit is transmitted by the arc frequency pattern beginning with 38 kHz, followed by 40 kHz, and ending with 36 kHz. A unique start bit, used to demarcate the beginning of a transmitted byte, is represented by a sequence in the arc frequency beginning with 36 kHz, followed by 38 kHz, and

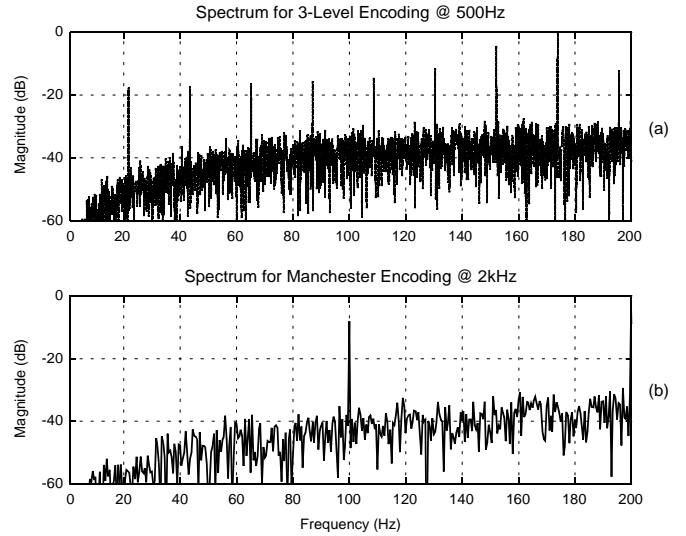

Fig. 4. Predicted frequency spectrum of lamp intensity.

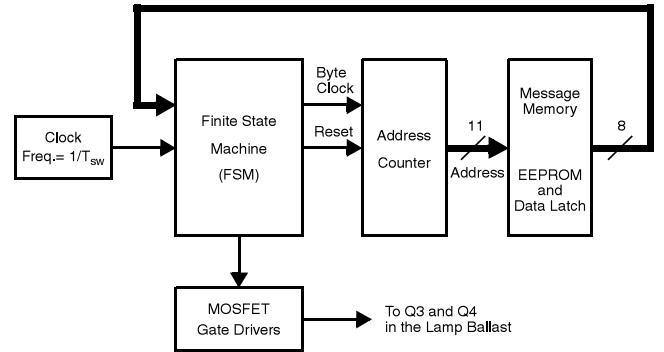

Fig. 5. Transmitter block diagram.

ending with 36 kHz.

The three-level patterns illustrated in Fig. 2 offer at least two advantages. First, the patterns for zero and one have the same average arc frequency. Thus, for sufficiently rapid switching between the different arc frequencies, i.e., for a sufficiently short interval T_{sw} , the lamp exhibits no perceptible flickering, even during transitions between long sequences of zeros and ones. Second, since the bit patterns exhibit a transition or frequency change every T_{sw} seconds regardless of the transmitted data, these transitions can be used by the receiver to generate a clock that synchronizes the receiver and transmitter. It is important to note, however, that the start bit pattern shown in Fig. 2 does not have the same average frequency as the logic zero and one patterns. As a result, the inevitable small flickering component at multiples of the byte rate may be accentuated. If the flicker at these frequencies is perceptible, a longer start sequence having the correct average frequency may be substituted with a slight reduction in throughput. This flicker was not observed in our prototype system.

A second coding scheme, Manchester coding, was also tested. Manchester coding is common in computer networks, and it is one of a class of half-weight block codes

that are suitable for this application (see [13].) The Manchester bit patterns are shown schematically in Fig. 3. This two-level code was set to shift the arc frequency in the prototype between 36 kHz and 40 kHz. Because the receiver was more adept at distinguishing the two-level Manchester patterns it was possible to reduce the timing period T_{sw} to 0.5 milliseconds. More detail is provided in the next section. The change increased the overall data rate by a factor of 4.6, which is a clear advantage. Manchester encoding is more difficult to synchronize and decode than the earlier three-level scheme, however, single-chip Manchester encoder/decoders from Harris and other manufacturers provide one simple solution.

No matter what encoding scheme is selected, variations in the intensity of the lamp output are inevitable. However, the two schemes just described ensure that the significant components of this variation occur at frequencies higher than the human eye can detect. Figure 4 shows approximate frequency spectrums of the lamp intensity for each of the two encoding schemes. The vertical axes, in decibels, are normalized with respect to the largest magnitude AC component. The spectrums were calculated assuming linear changes in intensity with frequency and a random stream of message data. Despite these rather broad assumptions the spectrums provide good qualitative estimates of the significant low-frequency components in the light output. Trace (a) shows intensity variations at multiples of 22 Hz for the three-level coding scheme. The lower frequency components at 22 Hz and 44 Hz are frequencies which might be perceptible to the human eye. Based on observations of the prototype we found these components to be imperceptible. The higher magnitude components (almost 20 dB greater than the lower frequency components), for example at 154 Hz and 176 Hz for example, are above the perceptible flicker frequency for the eye. Trace (b) shows the predicted spectrum using the higher rate Manchester coding. The first significant component in this spectrum appears at 100 Hz, which is already above the range of human perception. As might be expected, the light output appeared constant with both encoding schemes.

Figure 5 shows a block diagram of the transmitter. This transmitter is designed to broadcast a 2 kilobyte page of text, and then to repeat transmission of the page indefinitely. In general, messages could come from any digital or digitized source, however, there is an upper limit on the data rate; that is, T_{sw} must be significantly longer than the longest arc period in order for the receiver described in the next section to work reliably. In Fig. 5, a finite state machine (FSM) implemented with programmable array logic sets the arc frequency of the lamp by controlling the switches Q3 and Q4 in the ballast circuit. This FSM operates at a base clock period of T_{sw} and ensures that the arc frequency is altered once each period. The FSM also controls an address counter, which selects bytes of information stored in an EEPROM. The first seven bits of each byte contain an ASCII character code to be transmitted. The eighth bit signals the end of the page, which resets the address counter and triggers the FSM to start sending the

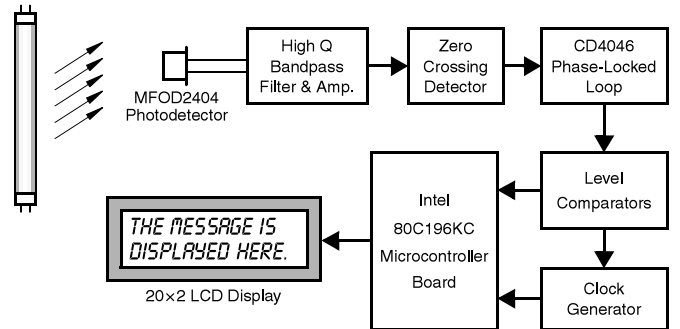

Fig. 6. Receiver block diagram.

message again from the beginning. Each bit in a byte is examined sequentially by the FSM, and the lamp arc frequency is controlled according to the bit patterns shown in Fig. 2 or Fig. 3. That is, the FSM “expands” each data bit into the appropriate pattern of arc frequencies.

III. RECEIVER

A Motorola MFOD2404 photodetector, with built-in preamplifier, is used in the prototype to detect the light output of the fluorescent lamp [14]. To help reject background variations in the ambient environment which are not caused by the operation of the transmitter, the photodetector signal is first passed through an analog band-pass filter and amplifier in the receiver. Note that, while the arc frequency varies from 36 to 40 kHz, the received intensity signal varies from 72 to 80 kHz, because the intensity varies with the magnitude and not the direction of the arc current. A block diagram of the receiver is shown in Fig. 6.

Zero crossings in the intensity signal are located using a comparator, and the frequency is tracked by a CD4046 phase-locked loop (PLL). The output voltage from the loop filter in the PLL switches between three distinct levels which correspond to the three possible detected arc frequencies, i.e., 72 kHz, 76 kHz, and 80 kHz. As shown in Fig. 6, the PLL loop voltage is digitized by two voltage comparators. The reference points for these comparators are set such that if the highest frequency is transmitted, then both comparators will go high. If the mid-range frequency is transmitted, then only one of the comparators will go high. Finally, if the lowest frequency is transmitted, then both comparators will go low. The two comparator outputs are fed directly into the microcontroller board. With an appropriate synchronizing clock, the microcontroller can decode the patterns observed in the comparator outputs in order to recognize transmitted bits.

For the three-level coding scheme, the receiver derives a synchronized clock signal from the incoming data. Four one shots are configured to fire on both the rising and falling edges of the comparator outputs. The one shot outputs are combined combinatorially to yield a clock with a period $\frac{T_{sw}}{2}$. Rising edges of this clock signal occur in the middle of each transmission period of length T_{sw} . The microcontroller samples the digitized PLL output on every rising

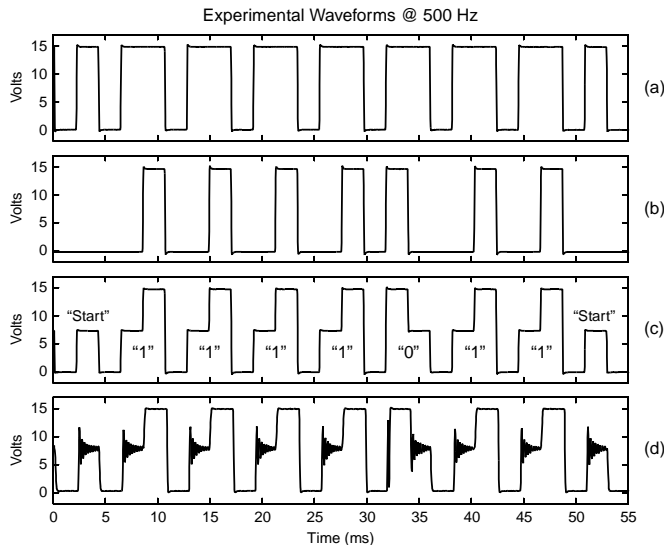

Fig. 7. Transmitted and received bit patterns with 3-level encoding.

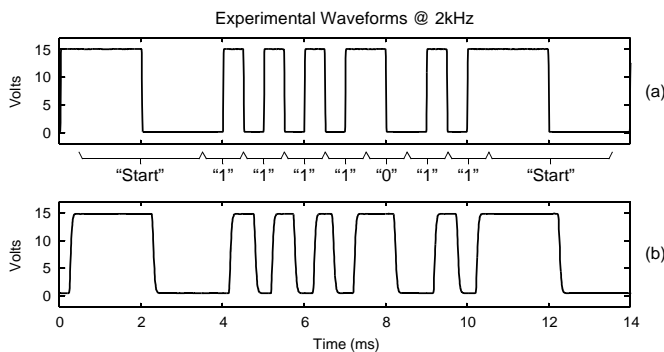

Fig. 8. Transmitted and received bit patterns with Manchester encoding.

edge of this clock, thus ensuring that the PLL has settled. Decoding of the Manchester encoded data is accomplished asynchronously by oversampling the comparator outputs and inspecting the received pulse widths. As mentioned earlier, this task is more easily accomplished using a number of single-chip decoders that are commercially available. In either case the microprocessor stores the decoded information and periodically updates the incoming message on a 2 line, liquid crystal display.

IV. EXPERIMENTAL RESULTS

A receiver was constructed using an Intel 80C196KC microcontroller (with plenty of spare processing power in this application). Code for the microcontroller was developed in the C programming language using a cross-compiler from Intel [7]. The transmitter and ballast circuitry were constructed as described in the previous sections on printed circuit boards. Additional details of the hardware and software are presented in [15].

Figure 7 shows some typical experimental waveforms during the transmission and reception of a byte using the three-level encoding scheme. The top two traces in the figure, labeled (a) and (b), are inverted versions of the

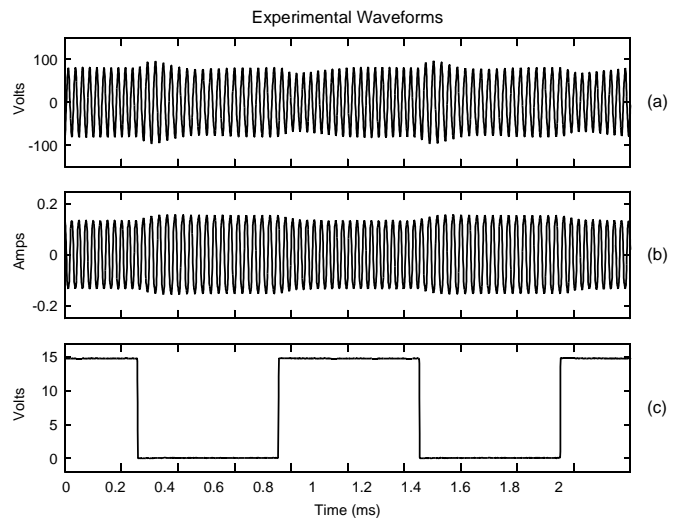

Fig. 9. Lamp voltage and current.

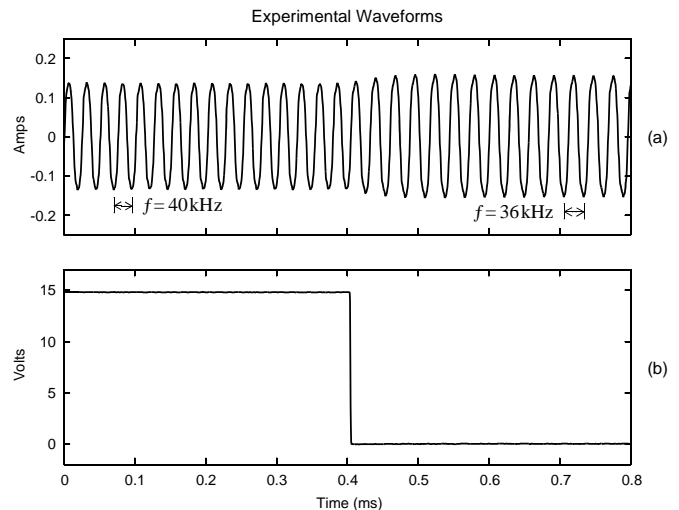

Fig. 10. Expanded view of the lamp current during a step change in frequency.

gate drive signals from the transmitter to the MOSFET's Q3 and Q4 in the lamp ballast, respectively. The third trace (c) is the sum of these two waveforms, i.e., the three-level modulation pattern that indicates the variation in the lamp arc frequency. The individual zero, one and start patterns are clearly visible. The data was captured during the transmission of the 7-bit binary number 1101111, which represents the letter "o" in the ASCII character set. With T_{sw} set at 2 ms a byte is sent every 46 ms, for a byte-rate of about 22 bytes-per-second. The fourth trace (d) is the received three-level message pattern measured at the output of the PLL loop filter. Traces (c) and (d) are essentially identical, as they should be. The mid-level oscillations found in trace (d) occur as the PLL re-acquires lock after a step change in frequency. These oscillations do not occur at the high- and low-frequency extremes because the PLL loop filter is tuned to saturate before achieving lock. It is this characteristic of the prototype receiver that

makes it possible to achieve a much higher data rate using the two-level Manchester encoding scheme.

Figure 8 shows similar experimental waveforms during the transmission of the same byte using Manchester encoding. Trace (a) is an inverted version of the gate drive signal to both MOSFET's Q3 and Q4 in the lamp ballast. The individual zero, one and start patterns are clearly visible in this waveform. In this case T_{sw} is set at 0.5 ms, transmitting a full byte every 10 ms, or about 100 bytes-per-second. Trace (b) is the received pattern measured at the output of the PLL loop filter. This waveform is smooth and absent of oscillations like those in Fig. 7 (d).

Figure 9 shows the voltage and current across the lamp while the transmitter is operating. Traces (a) and (b) in Fig. 9 show the terminal voltage across and current through the lamp, respectively, as the commanded arc frequency is changed. Trace (c) shows the voltage waveform corresponding to the commanded arc frequency, i.e., an expanded version of trace (a) in Fig. 8. Traces (a) and (b) in Figure 10 show expanded versions of the lamp current and the frequency command signal, respectively. The current is approximately sinusoidal, and is both frequency and amplitude modulated. The frequency modulation occurs in response to the action of the transmitter and ballast. The amplitude variations result from a slight detuning of the RLC resonant circuit in response to the commanded step changes in frequency. The transient variations which immediately follow a change in frequency are short-lived and do not significantly affect performance.

V. DISCUSSION

The fluorescent lamp transceiver set performs successfully. In operation, the transmitter sends the full 2 kilobytes of text stored in the page memory in approximately 20 seconds using Manchester encoding. The data rate is fast enough to refresh the 40 character display 2.5 times per second. Messages from the transmitter are decoded by the microcontroller in the receiver and displayed on the LCD screen. Other applications might use the data in different ways. For example, it would be perfectly reasonable to send bursts of audio information using this transceiver set. The receiver could collect a run of data bytes and reconstruct an audio message. We envision that a system like this could be used, for example, to provide low data rate location information to a person traveling in an unfamiliar building. Following a brief latency in each room or hallway to collect data, the receiver could provide visual or audio information (for a visually impaired person, for instance). This technique might also be used with HID lighting along roadways to provide street and direction information to moving vehicles. A receiver could also be constructed to provide digital data directly, e.g., as a receiver in a low bandwidth local area network.

The prototype transmits messages stored in an EEPROM, but other sources of input could be used. Coupled with a power-line carrier modem, the transceiver set could be used as a paging system that broadcasts messages in near real-time. A transmitter network could be constructed

in a building simply by installing new ballasts in existing fluorescent lamp fixtures, with no additional wiring. These fixtures make excellent transmission sources since they are designed to flood rooms with light, as opposed to custom wireless infra-red or low power radio-frequency transmitters.

Our prototype receiver does not employ automatic gain control (AGC) of the photodetector output. Hence, the receiver operates only within a relatively limited distance from the transmitting fluorescent lamp. A practical receiver would incorporate an AGC circuit to provide robust signal reception in an environment that might contain substantial background illumination. Also, the bit rate and arc frequency are conservative in the current design. Both could be increased with minor changes in the transceiver design to offer improved performance. Other bit patterns might improve the overall data transmission rate. A ternary coding scheme, for example, employed with the current system could increase the data rate.

Finally, we note that the current hardware could be improved or altered to provide other features. The general concept of varying the light output to transmit information could be incorporated into other ballast designs, including isolated ballasts. Clearly, the ease with which the frequency pulse code transmission scheme could be incorporated would depend in part on the chosen power electronic ballast topology. The two frequency data encoding schemes demonstrated in this paper are by no means the only approaches for coding data in the lamp output. Other techniques might be used to improve transmission bandwidth or flexibility. We envision that orthogonal bit patterns could be employed in different lamp ballasts (or the same ballast dependent on a transmission "key code") to permit the transmission and reception of data on different channels in the same local area. One channel could be used, for instance, to provide location information, while another might be used for direct person-to-person paging.

ACKNOWLEDGMENTS

This research was funded by MIT's Carl Richard Soderberg Career Development Chair and a CAREER Award from the National Science Foundation. Essential hardware for this project was made available through generous donations from the Intel Corporation, Tektronix, and Hewlett-Packard. The authors gratefully acknowledge the valuable advice and support of Professor Martin F. Schlecht and Rebecca A. Leeb.

REFERENCES

- [1] J. Waymouth, *Electric Discharge Lamps*, MIT Press, Cambridge, Massachusetts, 1971.
- [2] M. Dachs, "Optical Communication System," *U.S. Patent #3900404*, August 1975.
- [3] K. King, R. Zawislak, and R. Vokoun, "Boost-Mode Energization and Modulation Circuit for an Arc Lamp," *U.S. Patent #5550434*, August 1996.
- [4] M. Smith, "Modulation and Coding for Transmission using Fluorescent Lamp Tubes," *U.S. Patent #5657145*, August 1997.
- [5] K. Uehara and K. Kagoshima, "Transceiver for Wireless In-Building Communication System [sic]," *U.S. Patent #5424859*, June 1995.

- [6] W.M. Siebert, *Circuits, Signals, and Systems*, McGraw-Hill, New York, New York, 1986.
- [7] *80C196KC/80C196KD User's Manual*, Intel Corporation, Mt. Prospect, Illinois 1992.
- [8] K.H. Butler, *Fluorescent Lamp Phosphors*, The Pennsylvania State University Press, University Park, Pennsylvania, 1980.
- [9] A. Wilkins, I. Nimmo-Smith, A. Slater, and L. Bedocs, "Fluorescent Lighting, Headaches, and Eyestrain," *Lighting Research and Technology*, 1989, p. 11-18.
- [10] L.R. Nerone and M.Y. Najjar, "Analysis of the Class D Amplifier using a Two-Point Boundary Method," *Proceedings of the 27th Annual North American Power Symposium*, Bozeman, Montana, October 1995, pp. 442-446.
- [11] L. Laskai and I.J. Pitel, "Discharge Lamp Ballasting," *Tutorial Notes of the IEEE Power Electronics Specialists Conference*, Atlanta, Georgia, June 1995.
- [12] *IR2155 Data Sheet*, International Rectifier, 1996.
- [13] E. Bergmann, A. Odlyzko, and S. Sangani, "Half Weight Block Codes for Optical Communications," *AT&T Technical Journal*, Vol. 65, No. 3, May 1986, pp. 85-93.
- [14] *Optoelectronics Device Databook*, Motorola, 1987.
- [15] T.K. Buffaloe, "Fluorescent Lamp Optical Communication Scheme," Advanced Undergraduate Project Report, Department of Electrical Engineering and Computer Science, Massachusetts Institute of Technology, May 1996.
- [16] A. Moreira, R. Valadas, and A.M. Duarte, "Characterisation and Modelling of Artificial Light Interference in Optical Wireless Communications Systems," *Proceedings of the 6th International Symposium on Personal, Indoor and Mobile Radio Communications*, September 1995, pp. 326-331.



Deron K. Jackson (S'96) received the B.S. degree in electrical engineering from the University of California at Davis in 1991. He received the M.S. degree in electrical engineering from the Massachusetts Institute of Technology in 1994.

He is currently working toward the doctoral degree at the M.I.T. Laboratory for Electromagnetic and Electronic Systems. His research interests are in the areas of power electronics and control.



Tiffany K. Buffaloe received the B.S. degree in electrical engineering from the Massachusetts Institute of Technology, Cambridge, in 1996.



Steven B. Leeb (S'89-M'93) received the B.S., M.S., E.E., and Ph.D. degrees from the Massachusetts Institute of Technology in 1987, 1989, 1990, and 1993, respectively.

He has been a member of the M.I.T. faculty in the Department of Electrical Engineering and Computer Science since 1993. He currently serves as the Carl Richard Soderberg Assistant Professor of Power Engineering in the Laboratory for Electromagnetic and Electronic Systems. He is concerned with the design, analysis, development, and maintenance processes for all kinds of machinery with electrical actuators, sensors, or power electronic drives.

Dr. Leeb is a member of the IEEE Power Electronics, Control Systems, Power Engineering, and Signal Processing Societies. He is a Fellow of M.I.T.'s Leader's for Manufacturing Program and a member of Tau Beta Pi and Eta Kappa Nu.